

MPC Air-Cooled Chillers **MPC-FC Free Cooling Chillers**

1/2 - 100 Tons



- **Medical Equipment Cooling**
- **Industrial Process Cooling**
- **Mission Critical Cooling**
- **HVAC Cooling**



motivairTM

COOLING SOLUTIONS

www.motivaircorp.com



Motivaire is a world-class supplier of water chillers for medical equipment cooling, industrial process cooling and specialty HVAC systems. The MPC and MPC-FC chillers offer an unparalleled range of cooling capacities, and available options that allow customers to select a chiller best suited to their needs. Designed with four goals in mind; reliability, efficiency, flexibility and ease of use, the MPC range of water chillers have earned a quality reputation, trusted around the world to provide reliable cooling for critical applications.

MPC & MPC-FC CHILLERS

RELIABILITY

The MPC range of chillers is manufactured using the highest quality components. All components must pass a rigorous test cycle before being selected for production use. All fan & pump motors are TEFC or TEAO, and are therefore suitable for outside use. All electrical components are UL and CSA listed. MPC chillers are CE certified, and are also certified by ETL to be in compliance with UL 1995 and CSA C22.2 standards. The combination of innovative design, premium components, and universal certification yields a final product worthy of the most demanding cooling applications.



MPC-A 4000-7200

EASE OF USE

MPC chillers are designed for simplicity and ease of use.

- “Cycling” refrigeration circuit
- Integrated centrifugal circulation pump
- Large internal storage reservoir
- Microprocessor controls
- Integrated Free Cooling Option
- Single point power connection



MPC-A 0500

FLEXIBILITY

Process cooling and HVAC heat loads often change throughout the workday. The MPC range features a unique “CYCLING” design that allows the chiller to adapt automatically to any heat load from zero to 100% of its capacity. This cycling design utilizes a large storage reservoir, to insure close water temperature control regardless of the load, or the load change. The MPC evaporators are NOT immersed in the reservoir, and are therefore readily accessible for service, repair or replacement. The reservoir also acts as a buffer against temporary surge loads. Substantial energy savings can be achieved during low load chiller operation. MPC chillers do not utilize a hot gas bypass valve, common to other chillers, because these valves create an artificial heat load, which requires the chiller to operate when the load is reduced. The unique MPC cycling design also allows it to be used on multiple processes in a single building.

INDUSTRIAL AND COMMERCIAL APPLICATIONS

MPC INDUSTRIAL WATER CHILLERS

The MPC chillers can be applied to a wide range of industrial and commercial applications. Some common applications for MPC chillers include:

Oncology Machines

MRI Machines

CT Scan Machines

HVAC

IT Rooms

Pharmaceutical Mfg.

Plastics Processing

Printing Processes

Hydraulic Cooling

Welding Machines

Lasers

Metal Spraying

Food Processing



FEATURES:

- R-407C environmental friendly refrigerant
- High efficiency, stainless steel, brazed plate evaporators
- Stainless steel, centrifugal circulation pumps with close-coupled TEFC motors
- Oversized thermal storage reservoirs rated for 45 PSIG with fill, drain & vent ports
- Powerful, easy to use, non-proprietary microprocessors - "plug & play"
- Heavier frame construction – greater resistance to shipping, handling & operation abuse.
- Standard weatherproof enclosures on all models 5 tons and above.
- Removable access panels for easy service & maintenance
- Standard high-pressure and low-pressure refrigeration gauges 5 tons and above.
- Adjustable low pressure and fan pressure switches for flexibility in operation.
- Rotalock valves, liquid line solenoid valve & liquid receiver standard on larger models.

OPTIONS:

- Integrated Free Cooling
- 100% non-ferrous water circuit
- Laser (+/- 1°F) temperature controls
- High-pressure pump
- Duplex pump package
- Low ambient package
- High ambient package
- Castors for portability
- Centrifugal fans
- R-134A, R-410C, R-404A, R-507
- Remote control panel

DYNAMIC ENERGY SAVINGS

The Motivair MPC chillers all contain an oversized thermal storage reservoir. This unique feature allows the chiller to cycle its compressor(s) and fan(s) off during reduced process loads, while the pump runs continuously. This will maintain water temperatures within +/- 3°F of set point. Competitive chillers typically use a hot gas by-pass valve to balance the chiller capacity against reduced loads, therefore wasting energy and causing unnecessary wear and tear on the chiller.

REFRIGERATION COMPRESSORS

- Premium Maneurop compressors are standard on all models above MPC 0010
- 100% gas cooled compressor motor windings
- Resistant to liquid slugging
- Stronger mechanical construction allows maximum compression ratio of 12:1
- Low noise operation
- Superior anti-vibration mountings protect compressor & refrigerant piping
- 2 compressors in MPC 2200-3500; 4 compressors & dual circuits in MPC 4000 through 9000.

MPC-FC INTEGRATED “FREE-COOLING”

THE ULTIMATE SOLUTION FOR OPTIMAL ENERGY SAVINGS

The Motivair MPC-FC chillers with “Free-Cooling” capability are designed to provide the owner with optimal performance, year round, in varying ambient temperatures. This “Free-Cooling” option, available on models MPC 0800-9000 is supplied complete with pump and storage reservoir, “Free-Cooling” coil and the PCO3 advanced PLC control package – a unique single package for year-round energy savings.

The refrigeration plant is designed to cool the designated heat load during the highest summer temperatures. When ambient temperatures fall overnight or during cooler seasonal weather, the integrated “Free-Cooling” system is automatically activated. The system operates by directing the return chilled glycol through the “Free-Cooling” coil, before it enters the evaporator. This is achieved via an automatic motorized valve, controlled by the PLC,

whenever the ambient falls below the return chilled glycol temperature set point. The glycol is either partially or completely cooled in the “Free-Cooling” coil for maximum energy savings. As a result, less mechanical refrigeration is required to achieve the chilled glycol set point, and the refrigeration compressors are cycled off by the PLC, which continuously monitors the system.

Energy savings in areas with cooler winter months are substantial. Wear and tear on chiller components is dramatically reduced, due to fewer running hours during winter months. Automatic switching between mechanical cooling and “Free-Cooling” allows for optimal performance year round. As a general rule of thumb, “Free-Cooling” savings *more than pay for the initial investment in the first year of operation!*

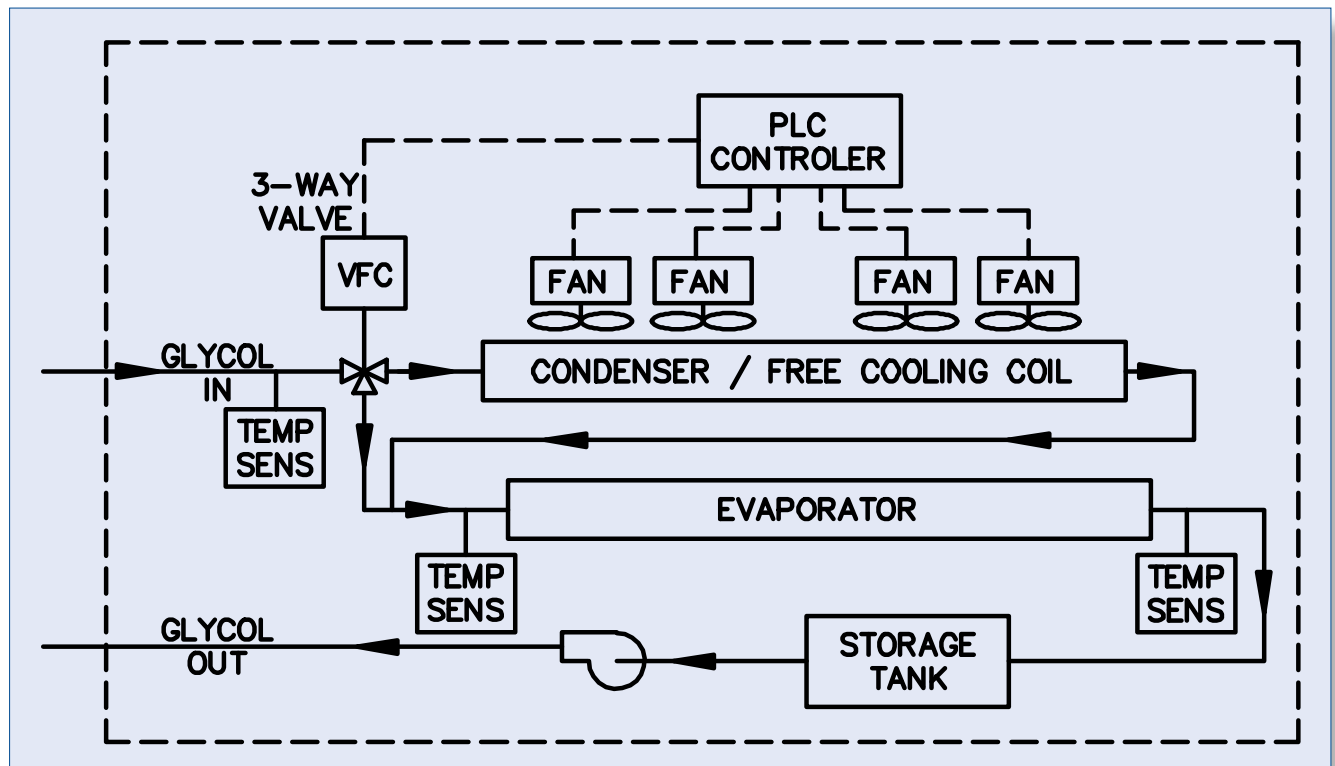

TAKE CONTROL OF YOUR MPC CHILLER...

THE MICROPROCESSOR

The standard Motivair microprocessor controller is a very powerful, yet user-friendly device. It offers a wide range of standard controls and alarms to suit any chiller application. It can control up to 4 stages of cooling in the chiller. Optional communication features include a serial card connection to a remote PC and a full-feature, remote wall-mounting controller, connected via an RS485 cable up to 500 feet away. For those applications requiring up to 8 cooling stages, and/or a higher level of remote communication, the PC03 advanced PLC system is available from the MPC 2200 and above.



Micro Chiller II



PC03 Display



PC03 Board

All MPC controllers feature a plug-in wiring harnesses, so they can be quickly and easily changed without tools.

MPC model	Standard	Optional
MPC 0005-0010	XR-10C	N/A
MPC 0150-0300	XR-10C	Micro
MPC 0500-1500	Micro II	N/A
MPC 2200-9000	Micro II	PC03

Standard Features and Alarms

	XR-10C	Micro	PC03
Highly visible digital display	x	x	x
Multi-character LCD display			x
Remote start/stop relay		x	x
General alarm relay		x	x
Supply water temp. display	x	x	x
Return water temp. display		x	x
Adjustable water set point	x	x	x
Adjustable alarm set points	x	x	x
°F/°C adjustable	x	x	x
Manual alarm reset	x	x	x
High refrigeration pressure alarm		x	x
Low refrigeration pressure alarm		x	x
Freeze alarm	x	x	x
Irregular voltage alarm		x	x
High water temperature alarm	x	x	x
Low water temperature alarm	x	x	x
Adjustable anti-compressor short cycle feature		x	x
Low water/glycol flow alarm		x	x
Compressor failure alarm		x	x
RS 232/RS 485 communication		consult factory	x
Ethernet communication			x
LON, BACNET, MODBUS communication		consult factory	x
Optional remote wall mount controller		x	x



Wall Mount Controller

MPC SPECIFICATIONS

AIR-COOLED	MPC-A	0005	0010	0150	0200	0300	0500	0800	1000	1200	1500	2200	3000	3500	4000	5000	6000	7200	8000	8500	9000
Capacity (1)	BTU/h	6,826	10,239	15,700	23,720	31,741	51,878	83,619	101,707	129,933	150,104	196,145	261,095	288,399	333,416	395,908	529,015	587,036	798,461	977,851	1,174,828
Current (Full Load Amps)	FLA	6.3	10.7	5.9	7.5	10.1	13.1	19.3	21.3	23.7	26.7	40.7	51.8	57.8	73.4	79.3	99.1	111.1	148	174	206
Axial Fans	Qty.	1	1	1	1	1	1	2	2	2	2	3	2	2	3	3	4	4	5	5	5
	Total HP	0.1	0.1	0.4	0.4	1.0	1.2	2.0	2.4	2.4	2.4	3.6	5.6	5.6	8.4	8.4	11.3	11.3	14.1	14.1	14.1
	Total CFM	824	765	2,178	1,942	2,943	4,415	7,063	6,887	8,005	7,652	13,508	18,011	18,011	29,136	28,253	37,082	35,316	77,000	77,000	77,000
Sound Pressure (4)	dBA	58	58	62.7	61.3	64.8	69.5	68.6	68.6	71.8	71.4	72.7	72.2	71.6	72.3	72.3	75.1	74.5	66.8	67.1	68.6
Net Weight (Shipping)	Lbs.	220	242	385	396	396	616	858	880	902	924	1,562	1,760	1,793	2,640	2,860	2,970	2,970	5,031	5,120	5,185
Net Weight (Operating)	Lbs.	330	352	539	550	550	814	1,562	1,584	1,606	1,628	2,475	2,673	2,706	4,290	4,400	4,620	4,620	6,905	6,993	7,210
WATER-COOLED	MPC-W	N/A	N/A	150	200	300	500	800	1000	1200	1500	2200	3000	3500	CF	CF	CF	CF	CF	CF	CF
Capacity (2)	BTU/h	N/A	N/A	16,966	25,618	34,280	56,028	90,308	109,844	140,328	162,112	211,837	281,982	311,470	CF	CF	CF	CF	CF	CF	CF
Current	FLA	N/A	N/A	5.5	7	9.5	12.5	16.8	18.8	21.2	24.2	36.2	44.2	50.2	CF	CF	CF	CF	CF	CF	CF
Condenser Water @ 85°F	GPM	N/A	N/A	3	4	6	8	12	16	19	23	31	38	44	CF	CF	CF	CF	CF	CF	CF
Net Weight	Lbs.	N/A	N/A	520	540	540	801	1,522	1,554	1,598	1,603	2,465	2,651	2,696	CF	CF	CF	CF	CF	CF	CF
FREE-COOLING OPTION*	MPC-FC							0800	1000	1200	1500	2200	3000	3500	4000	5000	6000	7200	8000	8500	9000
Cooling Capacity (1)	BTU/h	N/A	N/A	N/A	N/A	N/A	N/A	83,619	101,707	129,933	150,104	196,145	261,095	288,399	333,416	395,908	529,015	587,036	798,461	977,851	1,174,828
100% Free Cooling Ambient	°F	N/A	N/A	N/A	N/A	N/A	N/A	30	30	29	27	30	29	26	29	28	26	22	21	18	14
Net Weight (Shipping)	Inches	N/A	N/A	N/A	N/A	N/A	N/A	1,540	1,562	1,628	1,716	2,640	2,860	2,970	3,960	40,70	4,180	4,290	5,181	5,270	5,335
Net Weight (Operating)	Inches	N/A	N/A	N/A	N/A	N/A	N/A	2,398	2,420	2,530	2,640	4,290	4,400	4,620	5,280	5,500	5,720	5,830	7,055	7,143	7,210
Compressor		1	1	1	1	1	1	1	1	1	1	2	2	2	4	4	4	4	4	4	4
Refrigeration Circuits	Qty.	1	1	1	1	1	1	1	1	1	1	1	1	1	2	2	2	2	2	2	2
Electrical Supply	V/P/Hz	230/1/60		460/3/60																	
Tank Capacity	Gallons	11	11	18	18	18	18	78	78	78	78	101	101	101	101	130	130	130	130	130	130
Standard Pump	HP	1	1	2	2	2	2	2.5	2.5	2.5	2.5	4	4	4	5	5	5	5	10	10	12
Nominal Flow	GPM	1	2	3	5	6	10	17	20	26	30	39	52	58	67	79	106	117	202	248	299
Available Head	PSI	47	45	44	43	42	39	43	38	31	33	34	31	30	43	39	37	33	33	25	24
DIMENSIONS																					
MPC-A & MPC-W	Length	24	24	32	32	32	36	63	63	63	63	87	87	87	130	130	130	130	199	199	199
	Width	20	20	26	26	26	30	34	34	34	34	40	40	40	52	52	52	52	52	52	52
	Height	42	42	47	47	47	57	58	58	58	58	78	78	78	81	81	81	81	81	81	81
MPC-FC	Length	N/A	N/A	N/A	N/A	N/A	N/A	87	87	87	87	130	130	130	199	199	199	199	239	239	239
	Width	N/A	N/A	N/A	N/A	N/A	N/A	40	40	40	40	52	52	52	52	52	52	52	43	43	43
	Height	N/A	N/A	N/A	N/A	N/A	N/A	78	78	78	78	81	81	81	81	81	81	81	81	81	81
MPC-A, MPC-W Connections	NPT	1/2"	1/2"	1"	1"	1"	1"	1 1/4"	1 1/4"	1 1/4"	1 1/4"	2"	2"	2"	2.5"	2.5"	2.5"	2.5"	5"	5"	5"
MPC-FC Connections	NPT	N/A	N/A	N/A	N/A	N/A	N/A	1 1/4"	1 1/4"	1 1/4"	1 1/4"	2"	2"	2"	2.5"	2.5"	2.5"	2.5"	5"	5"	5"

* Capacity changes with operating conditions - Consult Motivair for assistance ** Consult factory for Free Cooling Dimensions

Notes (1) Air-cooled rating for 55F EWT; 45F LWT; 95F ambient temperature (2) Water-cooled rating for 55F EWT; 45F LWT; 85F condenser cooling water
 (3) Allow for piping losses when calculating cooling capacity (4) Measurement taken in open field, 10 feet away from chiller

MPC CAPACITY CORRECTION CHART

Capacity Correction Factors (cf)	(Multiply catalog capacities by correction factors)						
Chilled Water Temp. (°F)	23	32	40	45	50	55	60
cf1 °F	0.63	0.77	0.93	1	1.1	1.2	1.3
Ambient Temp. (°F)	85	90	95	100	Consult Motivair		
cf2 °F (MPC-A)	1.06	1.03	1	0.96			
Condenser Water temp. (°F)	75	80	85	90	95	100	105
cf3 °F (MPC-W)	1.06	1.03	1	0.96	0.93	0.9	0.87
Glycol % (by weight)	0	10	20	30	40	50	Consult
cf4	1	0.99	0.98	0.97	0.96	0.94	Motivair

APPLICATION, INTEGRATION & SOLUTIONS FOR ALL YOUR COOLING NEEDS:



MLC & MLC-FC

60-500 tons air-cooled, water-cooled & split system chillers for industrial or HVAC applications. Available Integrated Free-Cooling.



MHR

60-500 ton air cooled or water-cooled chillers with simultaneous heat recovery.



MSC SCROLL

Water-cooled scroll chillers with optional heat recovery from 15-60 tons



MCD Chilled Door™

Advanced rack cooling system fits any standard or OEM computer rack. Removes up to 45 kW of heat per door. Enhanced performance with Free Cooling chillers



PTS

Pump/Tank Stations for chillers and cooling systems



MOT & MEC

Open draft or closed loop evaporative cooling towers for process cooling or HVAC applications



MFC

Closed loop dry-coolers for process cooling and remote "Free-Cooling" applications

motivair™

25 John Glenn Drive
Amherst, NY 14228
Tel: 716-689-0222
Fax: 716-689-0073
www.motivaircorp.com